

Controlling POCKET GOPHER Damage



Pocket gophers are burrowing rodents which live almost entirely underground. Gophers are well adapted to their underground existence, with stout forelegs and strong curved claws for digging. They have prominent, yellow incisor teeth and large, fur-lined external cheek pouches in which food is carried. Pocket gophers have poor eyesight, but their other senses are acute. Their tails are sensitive and are used as feelers when the animals travel backward in their burrows.

Pocket gophers are rarely seen because they spend most of their lives in underground tunnel systems. Their presence in an area is indicated by the characteristic mounds they create. Pocket gophers should not be confused with moles, which are insectivorous and sometimes construct tunnels and mounds resembling those made by pocket gophers.

Gophers are solitary animals except during the mating season and when young are being cared for. Otherwise, there is only one gopher in each tunnel system. Pocket gophers dig extensive tunnels or runways that consist of a main tunnel with several short lateral tunnels. A single gopher may have a burrow system that extends as much as 800 feet, covers an acre of ground, and ranges from a few inches to several feet deep. Runways vary from 2 to 5 inches in diameter depending on the gopher species. These runways serve as homes, storehouses and routes for underground searches for food. The shallow run-

ways, 4 to 15 inches below the surface, are used primarily to search for food. The gopher pushes soil from the burrows to the surface with its forefeet and chest, forming a characteristic horseshoe shaped mound approximately 8 to 24 inches in diameter and 6 inches high. The mounds are at the ends of short, lateral tunnels which branch off the main runway. The surface opening, used to expel dirt from the burrow, is plugged by pushing dirt into it. This results in a depression on one side of the mound (Fig. 1).

The pocket gopher's diet mainly consists of fleshy roots of various plants, including trees. Gophers normally eat tubers such as potatoes and peanuts. They also eat green tops and seeds that can be pulled down into their burrows.

Biology and Reproduction

Adult weight: Up to 1 pound.

Total length: 6 to 13 inches.

Color: Light brown to deep chocolate.

Body: Stocky, short-legged.

Gestation period: Depending on species, 18 to 51 days.

Litter size: Ranges from one to six, averaging two.

Litter number: May have two per year, usually born from March to July.

Life span: 1 to 2 years.

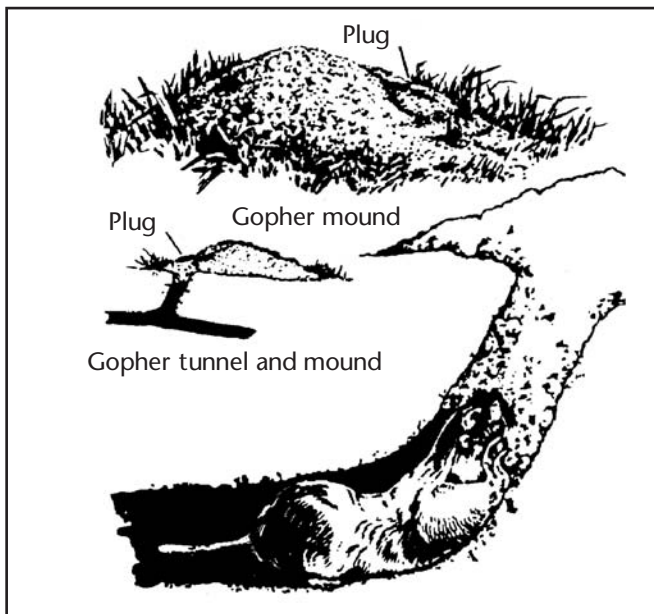

Figure 1. Pocket gopher using nose and front feet to tamp earthen plug to tunnel.

Effects of Pocket Gophers

Under natural conditions, gophers are beneficial to the soil. It is estimated that in a year, one gopher transports 2½ tons of soil to the ground surface. By bringing subsoil to the surface where it weathers more quickly, gophers contribute to the soil building process. The loosened soil makes the ground more fertile. Air and water can easily pass through porous soil to plant roots.

Gophers can cause serious damage when they establish tunnel systems in cultivated farming areas, rangelands, orchards, tree farms and lawns. When there are many gophers they can damage field and pasture crops by eating the crops and by forming mounds which interfere with farm machinery. Gophers reduce the amount of livestock forage available on rangeland by harvesting and burying vegetation. They gnaw or clip the roots of trees, which may kill seedlings or small trees and reduce the vigor of large trees.

Pocket gophers in a lawn, garden or flower bed can destroy plants and produce unsightly mounds. Gophers gnaw through underground plastic water pipes and electrical and communications cables, and interfere with irrigation dikes. A tunnel system in a dam can cause it to erode and wash out. Tunnels under paved highways may cause the pavement to sink.

Controlling Pocket Gophers

Control operations should be conducted during the spring and fall when pocket gophers are most active near the surface. Their activity is usually indicated by the presence of fresh mounds of dirt. Control operations in the fall interfere the least with growing crops. Methods of control include mechanical and chemical means.

Mechanical Control

In small areas such as yards or gardens, where there are only a few pocket gophers, trapping is usually satisfactory. Special traps have been designed to capture gophers. Several different types are available at hardware or farm and ranch supply stores (Fig. 2). Because success

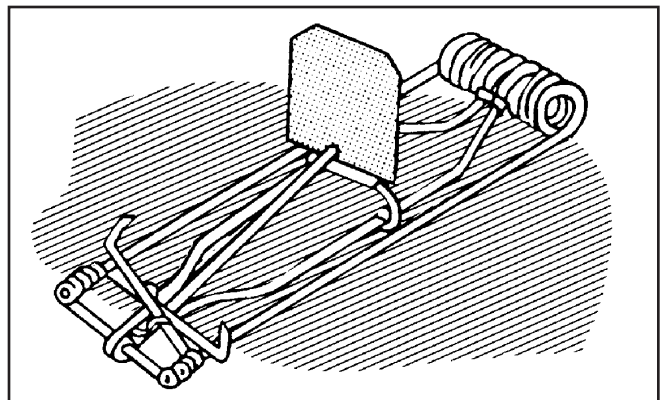

Figure 2. Macabee gopher trap.

depends upon the proper use of traps, the following steps are suggested:

1. Locate the newest mound or series of mounds.
2. Locate the main runway by probing the soil with a bluntly pointed probe, 6 to 8 inches from the mound on the side where the horse-shoe-like depression is found (Fig. 3). When the probe drops into the runway, the release of ground friction will be felt.

A probe can be made from a bluntly pointed broom or shovel handle. Excellent probes are made with a 3-foot section of a ¾-inch gas pipe welded to a blunt point. Thread the cut end and fit it with a "T" joint. Four-inch nipples with the threads cut off of one end can be screwed into the "T" joint to form a handle. A moveable foot rest can be made of a 1-inch "T" joint slipped over the main probe and held in place with a set

Chemical Control

Effective control materials for gophers are strychnine-treated grain and zinc phosphide pellets. Toxic baits can be administered by the hand probe method or with a burrow builder. These methods are most efficient for large or heavily infested areas where trapping is not practical. Because the toxic

grain is placed underground, it is relatively safe when used around other wildlife, pets and livestock. However, you should always carefully read and follow pesticide label instructions. Some of these products are classified as "restricted use" and require a certified pesticide applicator's license.

Hand Baiting

Two techniques are used to locate main runways so that bait can be properly placed. The first method is the same as the one described under "Mechanical Control." The second is to probe the area in a perpendicular line between two fresh mounds, assuming that the main runway makes a direct connection between them.

After locating the main runway, remove the probe and insert the recommended doses of bait material. Close the opening with grass or paper and cover it with dirt to keep out light and air. Do not cover the bait with soil. Determine the overall extent of the individual main runway. Place bait near each end, as well as at one or more locations in the central part of the system.

In predominantly sandy soil, or whenever the runway is difficult to locate with a probe, locate the burrow plug at the mound. This can be done by carefully scraping the dirt from a fresh mound until a round circle of fresh dirt is found plugging the lateral runway. Open the lateral to the main runway with a long handled spoon and insert the recommended dosages of bait. Plug the surface opening with grass or heavy paper and cover with dirt. A relatively simple way to find sur-

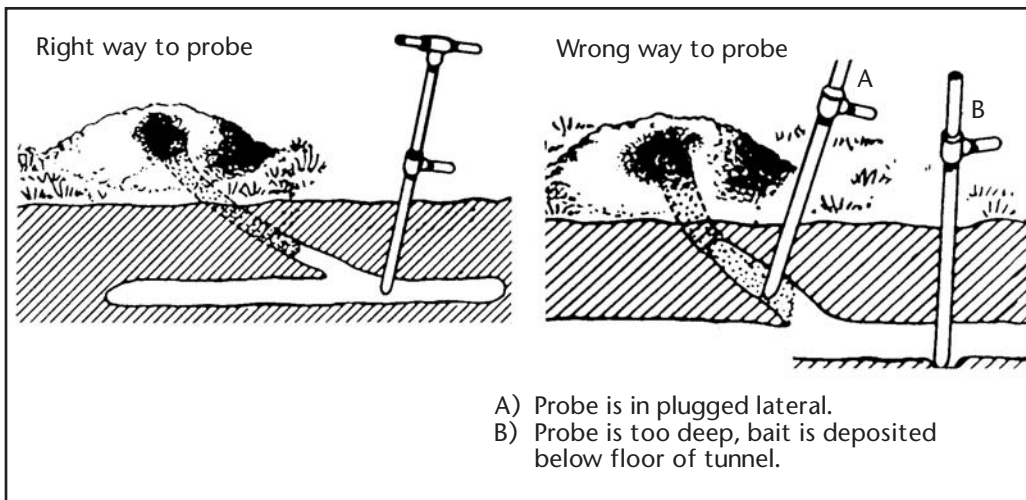

Figure 3. Right way and wrong way to probe.

screw. A 4-inch nipple screwed into the "T" completes the foot rest.

3. Dig down with a trowel or shovel to locate the runway. The traps should be placed as far into the tunnel as possible. It may be necessary to enlarge the runways to allow the traps to operate properly. Leave the hole open, because the gopher will be attracted to the opening to plug it.

4. Secure the trap with a piece of small, flexible wire attached to a stake so the gopher cannot pull it into the tunnel.

5. If traps are set in the main runway, set and place two traps, one in each direction from the hole (Fig. 4A). If traps are set in lateral runways, unplug the tunnel entrance at the mound. Place one trap, jaws forward, in the lateral tunnel with the trap jaws pointing toward the main runway (Fig. 4B). Do not block the main runway.

6. For best results, visit the trap-sets every half-hour.

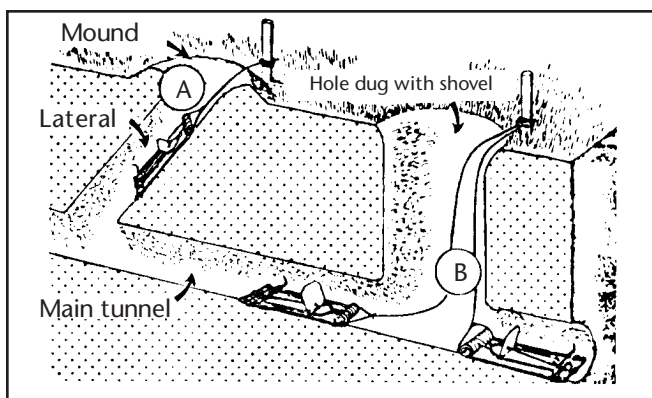

Figure 4.

vivors is to level all fresh mounds after baiting. Fresh mounds can then be identified and re-baited as necessary.

Burrow Builder Baiting

The burrow builder constructs an artificial burrow and, at the same time, dispenses bait underground (Fig. 5). It is attached to a tractor

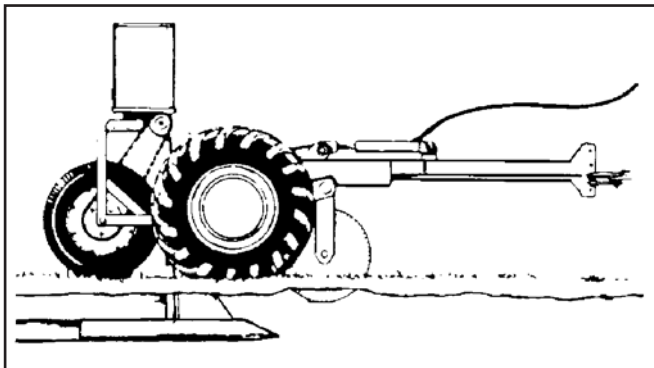

Figure 5. Burrow builder.

and pulled back and forth across a field to make a series of parallel burrows. The gophers will explore the artificial burrows and find the poison bait. The soil must have good plowing moisture for effective construction of artificial burrows. If the soil is damp enough that a handful will hold its shape when compressed, it is suitable for using the burrow builder. Constructed burrows should be at the average depth of the natural gopher burrow. Effective treatment depends upon gophers finding the artificial burrows and using them long enough to find the bait.

Burrows should be made at 25- to 30-foot intervals along the contour of the land. For best results, boundary and fence lines also should be treated. If the gopher infestation is moderate to light, effective control is possible with burrows baited at 40- to 50-foot intervals. If spot treatment is all that is needed, use the burrow builder only where mounds are visible, or along boundary fence lines. Always follow the label directions carefully.

If orchard or forest seedlings are to be planted in areas where gophers are present, the area should be treated before planting as if for heavy infestation of gophers. Treat as needed halfway between the tree rows to prevent root damage.

Fumigants

Fumigants have limited use for controlling pocket gophers. The extent of the burrow system, the chance for leakage of gas through the softer earth in laterals, the closeness of the main runs to the soil surface, and the fact that gophers may quickly plug their burrows when toxic gas is detected, makes the use of fumigants unsatisfactory.

For additional information contact the nearest office of Texas Cooperative Extension–Wildlife Services.

TCE–Wildlife Services
P.O. Box 100410 • San Antonio, Texas 78201-1710

The information given herein is for educational purposes only. Reference to commercial products or trade names is made with the understanding that no discrimination is intended and no endorsement by the Cooperative Wildlife Services Program is implied.

Extension programs serve people of all ages regardless of socioeconomic level, race, color, sex, religion, disability, or national origin.
Wildlife Services is a program of Texas Cooperative Extension cooperating with the United States Department of Agriculture–
Animal and Plant Health Inspection Service–Wildlife Services.